

Quick Guide



Calibrex™ universal 520



Material list
and chemical
resistance

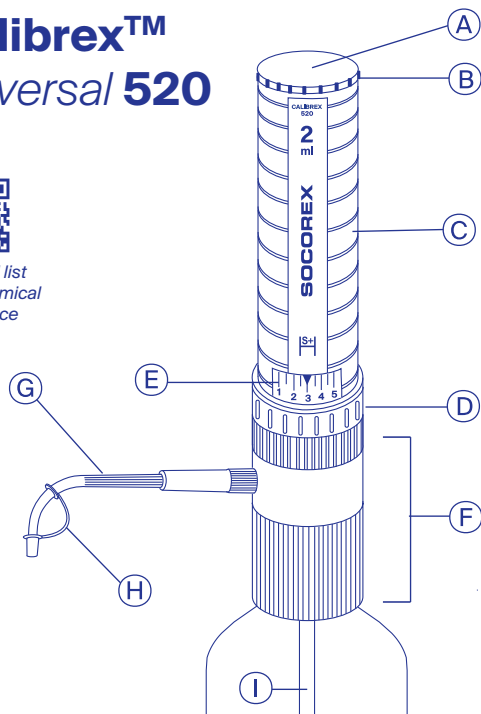

- A** Cap **B** Plunger head **C** Dispenser body **D** Volume setting wheel **E** Volume display **F** Connecting body **G** Delivery jet **H** Stopper with strap **I** Feed tube

Related items	Packaging	Cat. No.
Universal support for Calibrex™ 520/525/530 dispenser	1 / pk	320.SB150
Replacement feed tubing, 30 cm, PTFE, int. Ø 5 mm	1 / pk	511.707
Telescopic feed tubing, FEP (150 – 255 mm, Ø ext 6.5 mm, Ø int 5 mm)	1 / pk	1.525.352
Threaded adapter (PP) (Ø 22, 25, 28, 30, 34, 36, 38, 40, 45 mm)	1 / pk	GLPxx



Package contents

Dispenser, feed tubing 300 mm, delivery jet, base thread 32 mm, adapters 28, 40 and 45 mm, QC certificate, Quick Guide.

Safety precautions

- Read carefully and observe manufacturer's instructions, guidelines and chemical compatibility limits.
- Refer to and follow regulations about handling of potentially hazardous reagents.
- Always control proper working, tightness and bottle stability.
- Delivery jet should never point towards a person.
- Seized parts should not be separated by applying force.
- Prime and rinse dispenser carefully before disassembling any part or prior to storing.
- Take adequate measures to avoid electrostatic discharge when dosing flammable liquids.
- When using small reagent bottles or extension tubing, use workstation to secure dispenser stability.
- Operating temperature: 15°C - 40°C (60°F - 105°F).
- This instrument should be used only for precise and repeatable dispensing of liquids in a laboratory.

Step-by-step instructions

1. Preparing for work

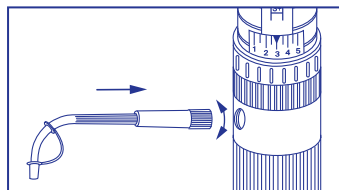

Screw on delivery jet adapter nut without forcing.

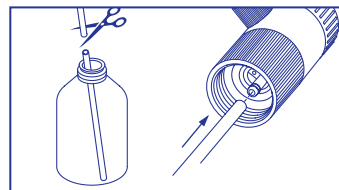

Cut feed tube according to bottle size and attach to dispenser.

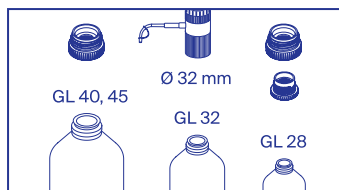

Install dispenser on bottle using appropriate adapter if needed. Other adapter sizes are optional.

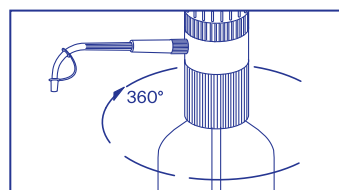

Rotate delivery jet to find optimal position.

2. Volume setting

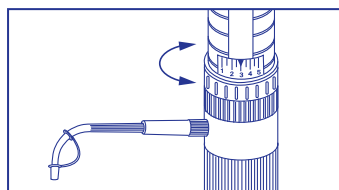

Turn setting wheel to set desired volume. Clic-stop mechanism prevents unexpected volume alteration.

3. Priming

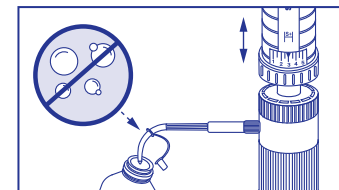

Remove stopper. Slowly activate dispenser several times (short strokes) to eliminate air bubbles in system.

4. Dispensing

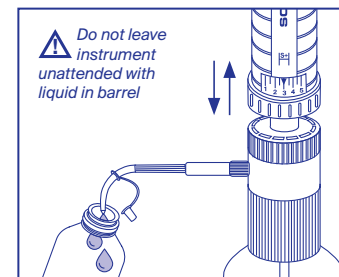

Move plunger gently and regularly between upper and lower stops to dispense liquid.

After finishing, purge and rinse instrument carefully. Put stopper back on.

Most common troubleshooting

Observation	Possible cause	Solution
Liquid aspiration impaired	Plunger blocked by crystallization or dried residues	Never apply force to resolve; soak dispenser in warm water or mild laboratory detergent; move parts gently
	Valves untight due to residues on ball or valve body	Clean valves, use ultrasonic bath to remove residues
Erratic plunger movement	Plunger damaged due to improper cleaning or usage with inappropriate chemicals	Replace plunger; follow cleaning instructions; check chemical compatibility
Liquid leakage	Loose connecting screws	Tighten all connections without excessive force
Compromized performance	Liquid out of accepted viscosity	Check operating instruction for viscosity limits

Scan to access operating instructions



EN / DE / FR



IT / ES / PT